

TM-1/TM-1P Machine Layout Drawing

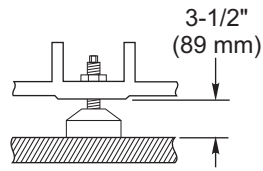

4X Leveling Pad Pin Dimension

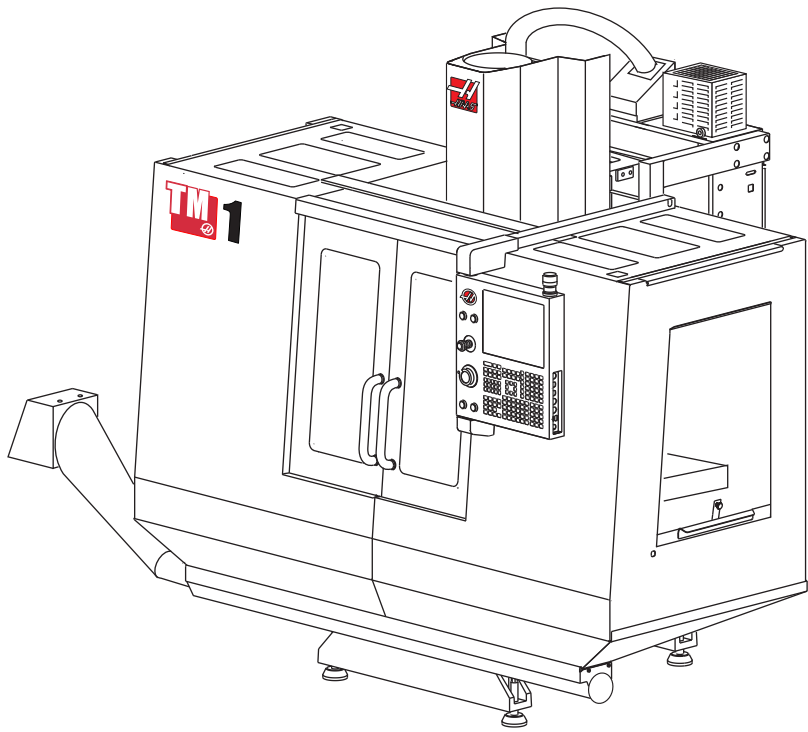

(4X) Ø1-1/2 x 8-1/2" DP
(4X) Ø38 x 216 mm DP

Note:
Foundation must extend
at least 1 ft. (305 mm)
from bored holes.

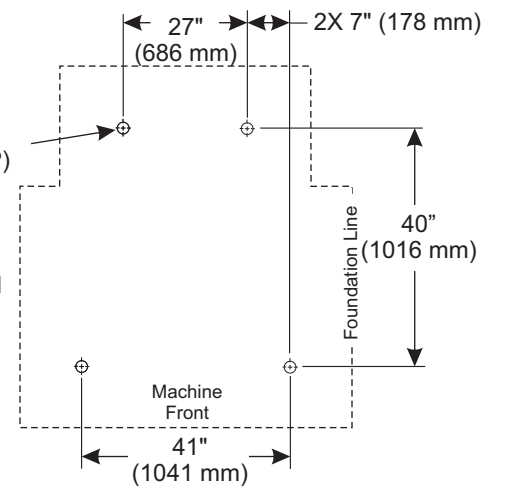

TM-1 Anchor Pattern

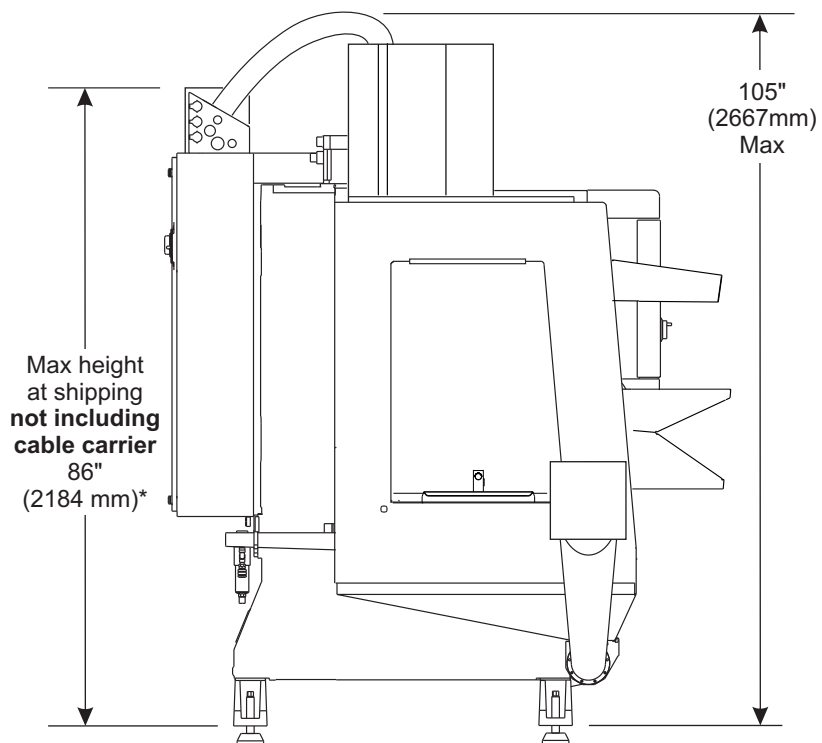
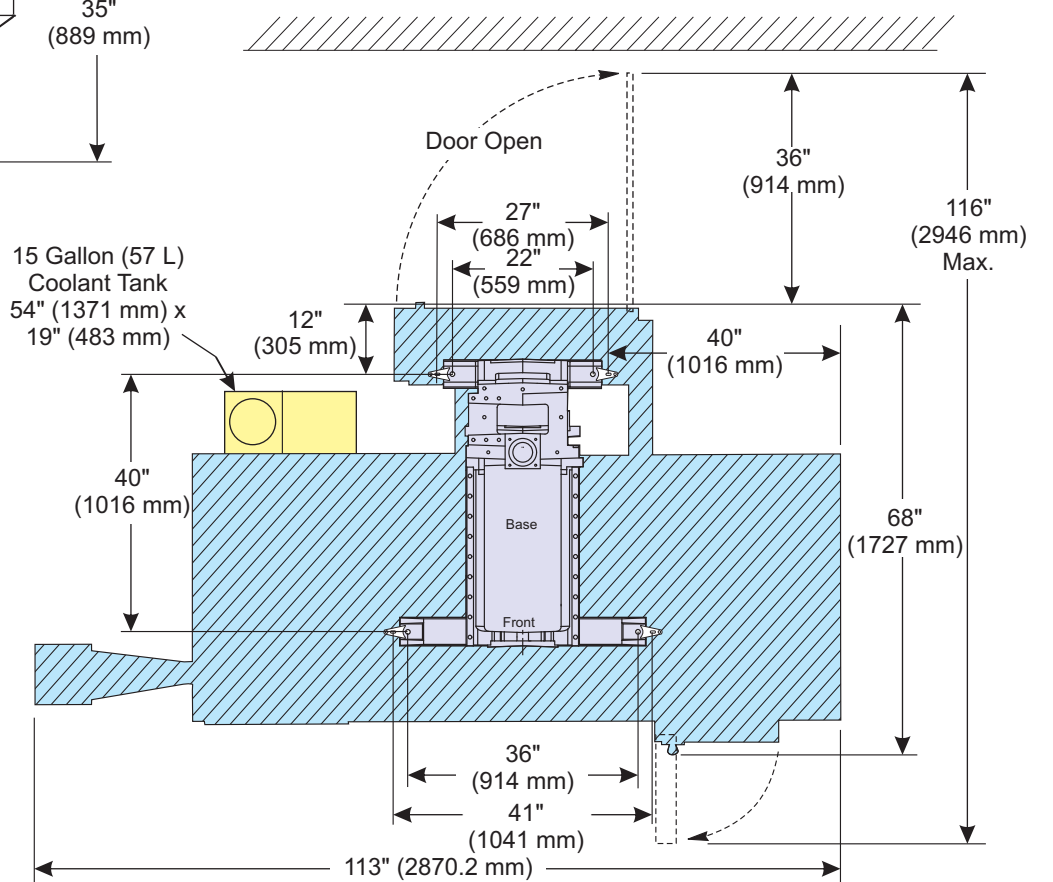
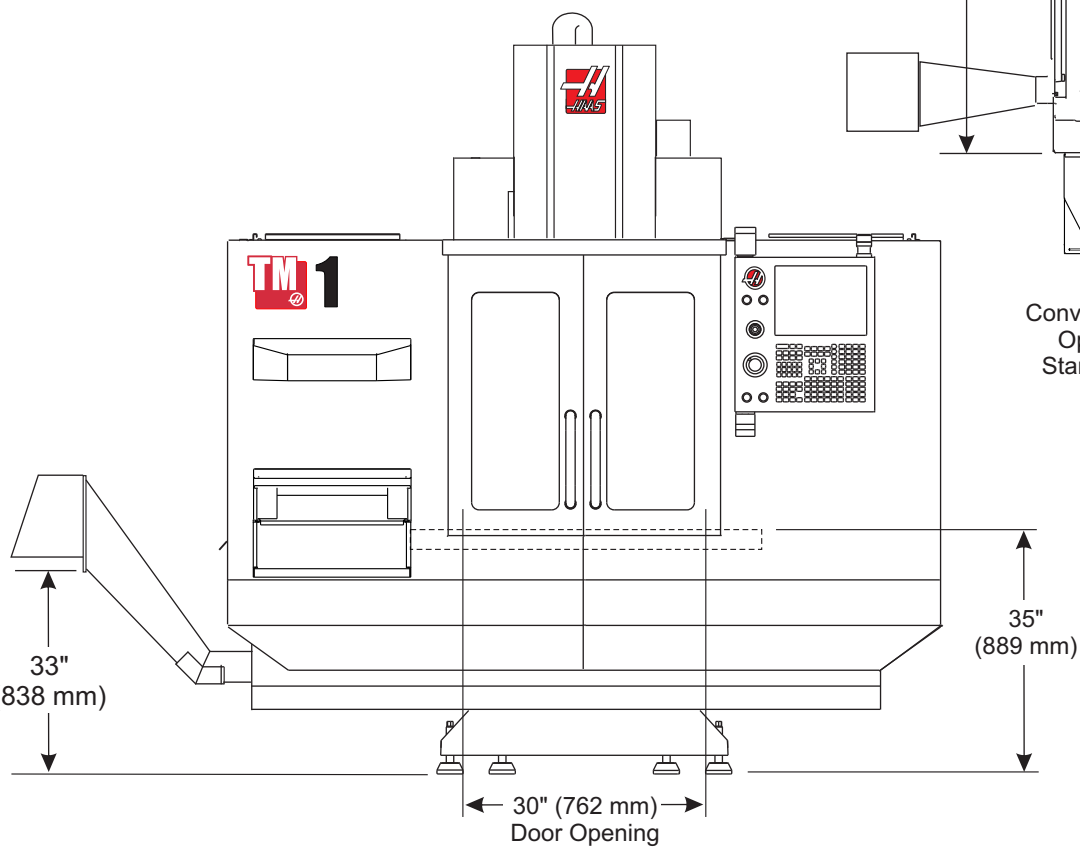
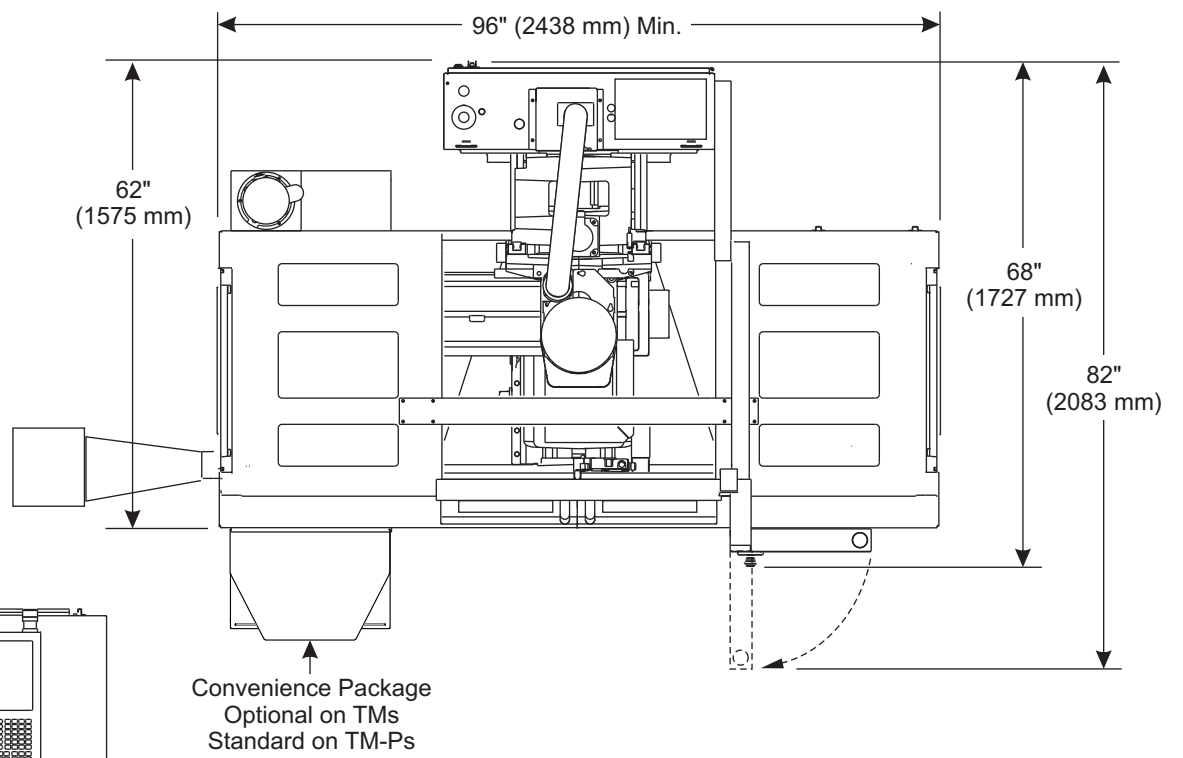

* The lowest the machine can be broken down to is 84" (2134mm) leaving the feet on; 78" (1981 mm) with the feet removed

TM-1/TM-1P Machine Layout Drawing

TM-1 Enclosure Work Space

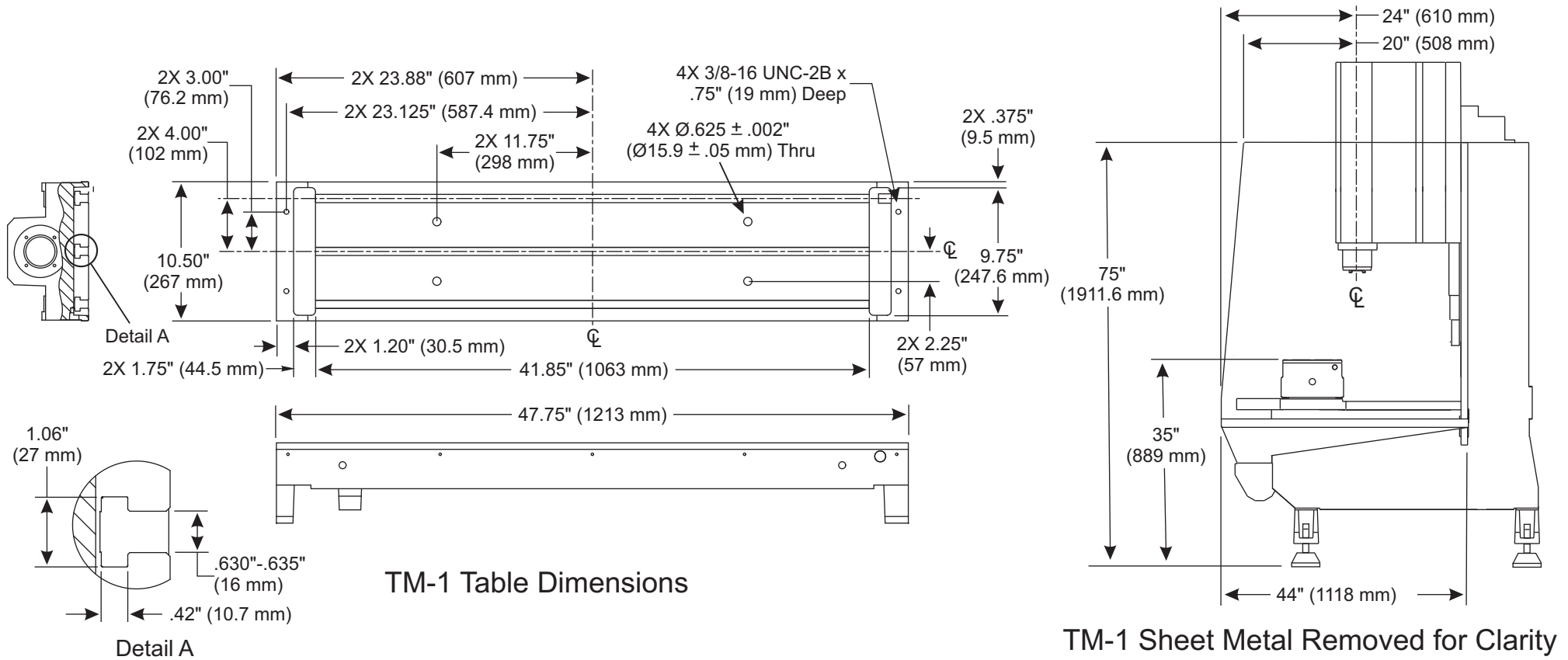

Detail A

TM-1 Sheet Metal Removed for Clarity

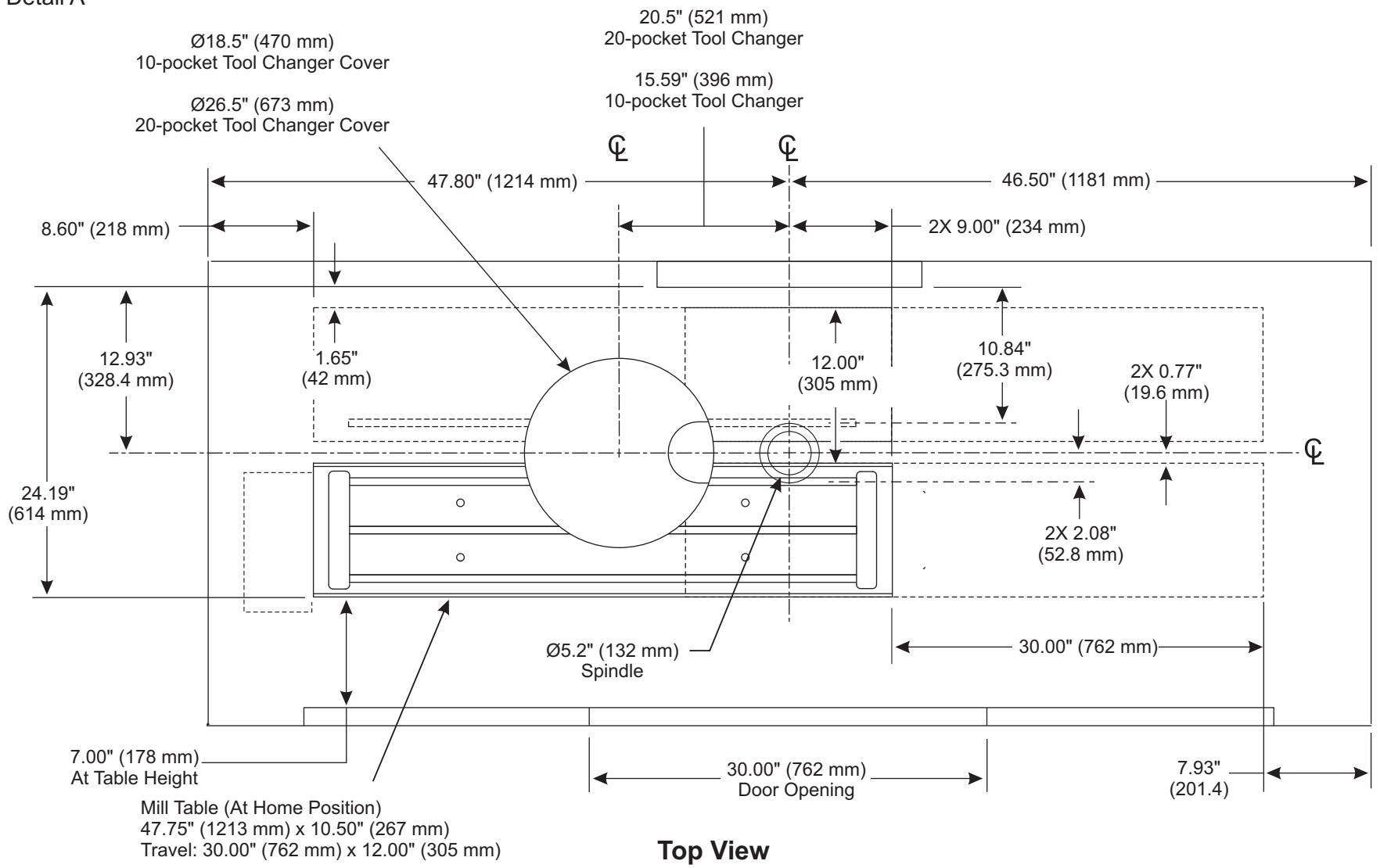

Top View

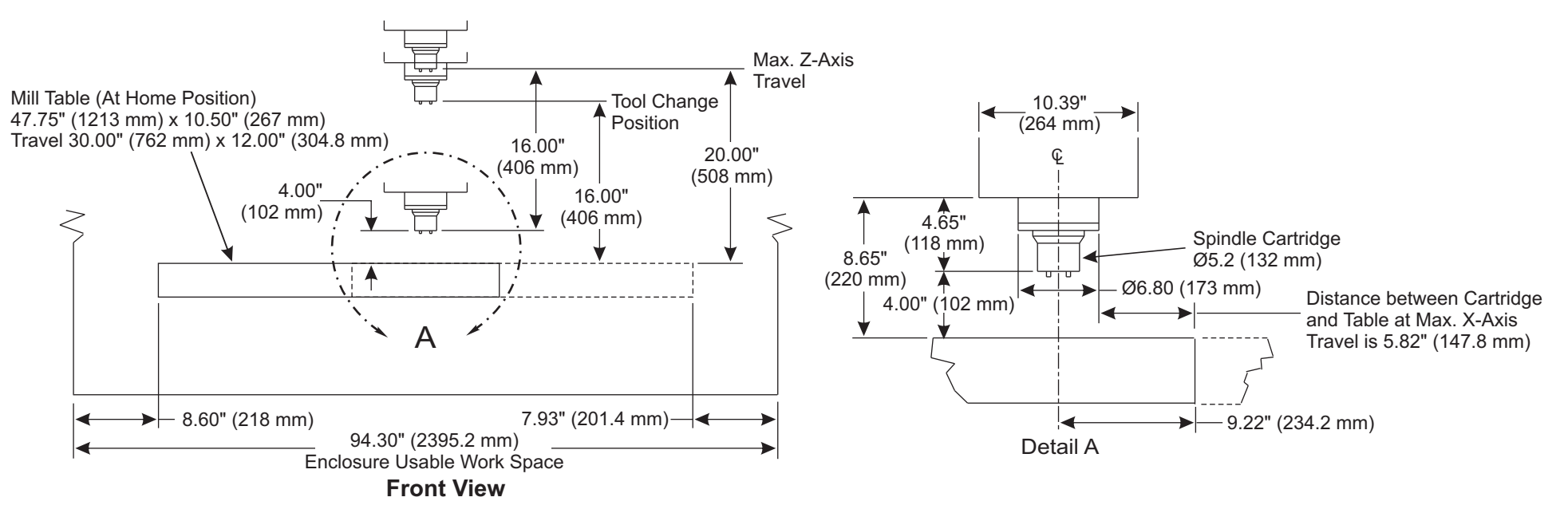

Front View

Detail A